

# Vector Frame Kit 04

## VF-K-04

Stand apart from the competition with a state-of-the-art, modern Vector Frame Kit. The Vector Framel Kit series is a collection of extrusion-based, dye-sublimated fabric mural graphic displays. Vector Frame Kits are easy to assemble and dismantle.



## features and benefits:

- Heavy-duty 50mm silver extrusion frame
- Single-sided SEG dye-sublimated fabric graphics
- Easy step-by-step instructions
- Kit includes frame, five fabric graphics, four 120 watt floodlights, two wheeled molded cases, and one enclosed fabric graphic counter
- Lifetime hardware warranty against manufacturer defects

## dimensions:

Hardware	Graphic
<p>Assembled unit: 113.25" w x 94.5" h x 22" d approx. 2900mm(w) x 2400mm(h) x 560mm(d)</p> <p>Counter: 39.375" w x 36.625" h x 22.25" d approx. 1000mm(w) x 930mm(h) x 570mm(d)</p>	<p>Panels A, B, D, E: Total visible area: 17.72" w x 94.5" h 450mm(w) x 2400mm(h)</p> <p>Panel C: Total visible area: 70.866" w x 94.5" h 1800mm(w) x 2400mm(h)</p>
<p>Shipping</p> <p>Shipping dimensions - ships in 2 cases Each OCH2 case: 52" l x 30" w x 15" h 1320mm(l) x 760mm(w) x 380mm(h)</p> <p>Approximate shipping weight (entire kit): 200 lbs/90.7 kg</p>	<p>Counter panels A, C: Total visible area: 17.72" w x 35.43" h 450mm(w) x 900mm(h)</p> <p>Counter panels B, D: Total visible area: 35.43" w x 35.43" h 900mm(w) x 900mm(h)</p> <p>Refer to related graphic templates for more information</p>

## additional information:

Graphic material:  
Dye sublimated fabric

Tabletop color options:



silver



black



mahogany



natural

Counter holds max weight 100 lbs/45.4 kg

Lights included: Lumina 200 120 watt floodlight, curved arm, black finish, 19.5" from end to end

We are continually improving and modifying our product range and reserve the right to vary the specifications without prior notice. All dimensions and weights quoted are approximate and we accept no responsibility for variance. E&OE. See Graphic Templates for graphic bleed specifications.

Parts included		
Part Label	Qty	Part code
F2	x2	PH-1155-S-L1
F6	x8	PHFC2-1200-2L
F7	x4	PHFC2-1200-2
F8	x8	PHFC2-1200-2L
F13	x2	PHFC2-900-2
F15	x2	PHFC2-900-2
F17	x8	PHFC2-450-1
VE-39	x8	PM2S-1200-A-A
VE-45	x4	PH4-300
Panel A	x1	-
Panel B	x1	-
Panel C	x1	-
Panel D	x1	-
Panel E	x1	-
Corner lock	x20	CB9
Lock connector	x13	IB2
Light	x4	-
Tool kit	x1	V-TK-01
Steamer	x1	FABRIC-STEAMER
Step stool	x1	STEPSTOOL

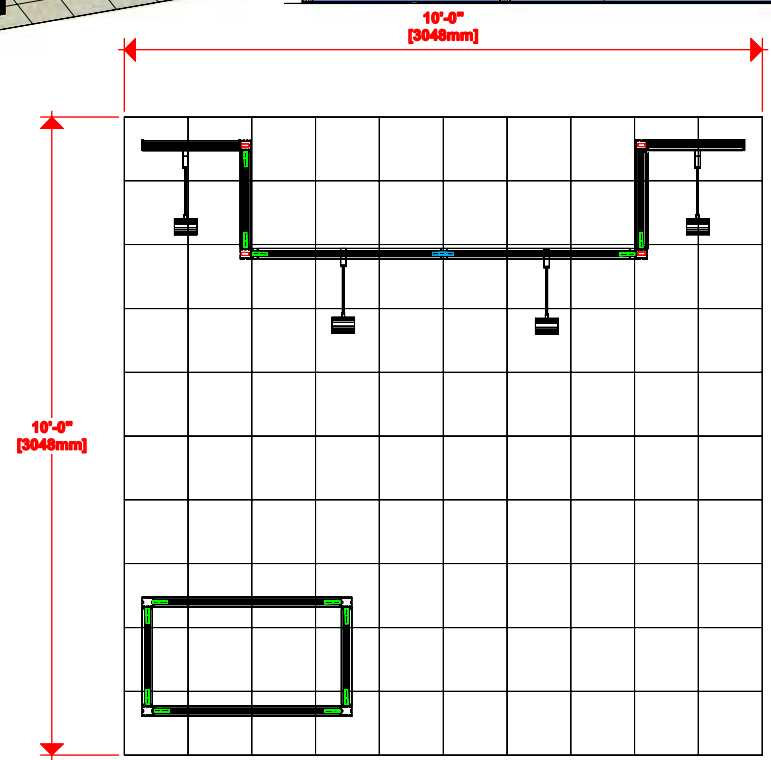
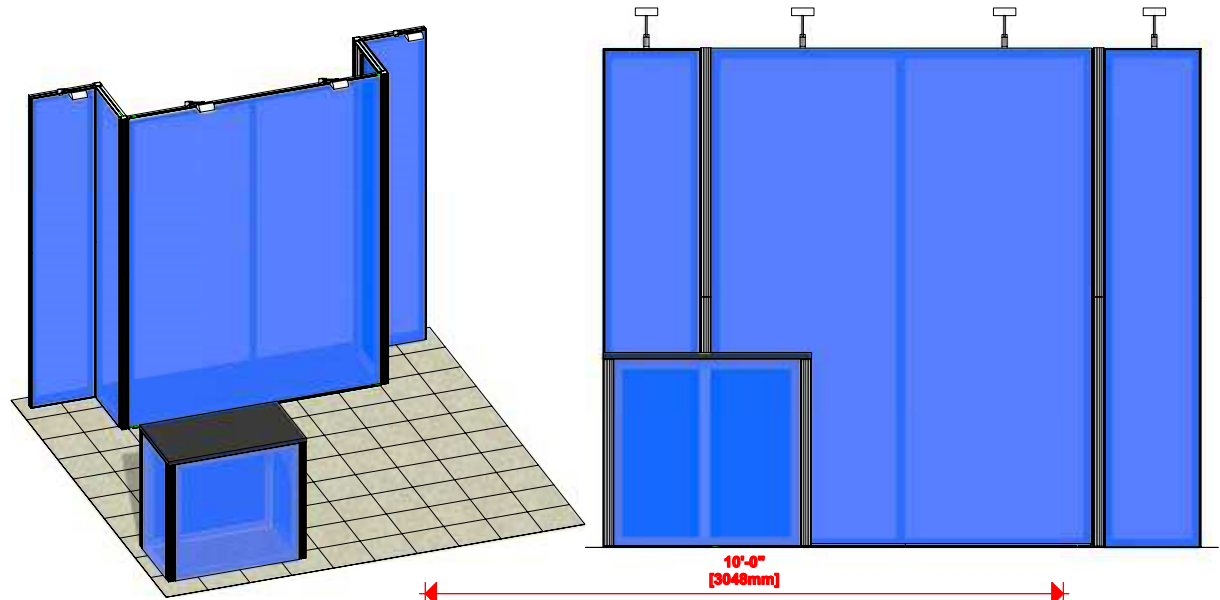

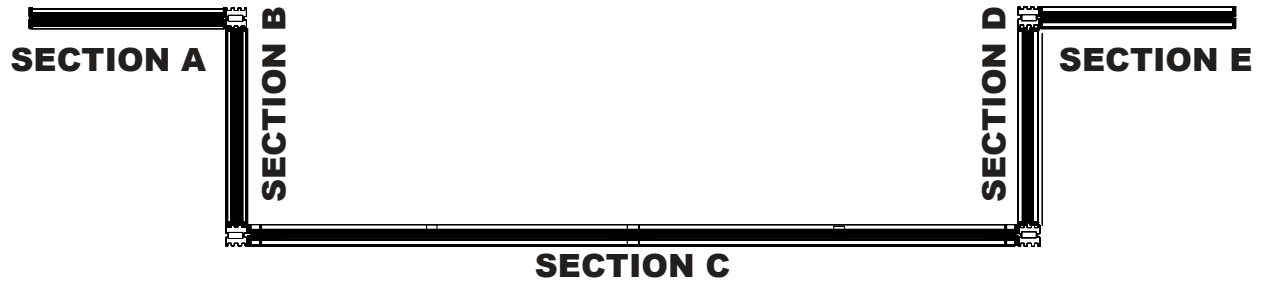
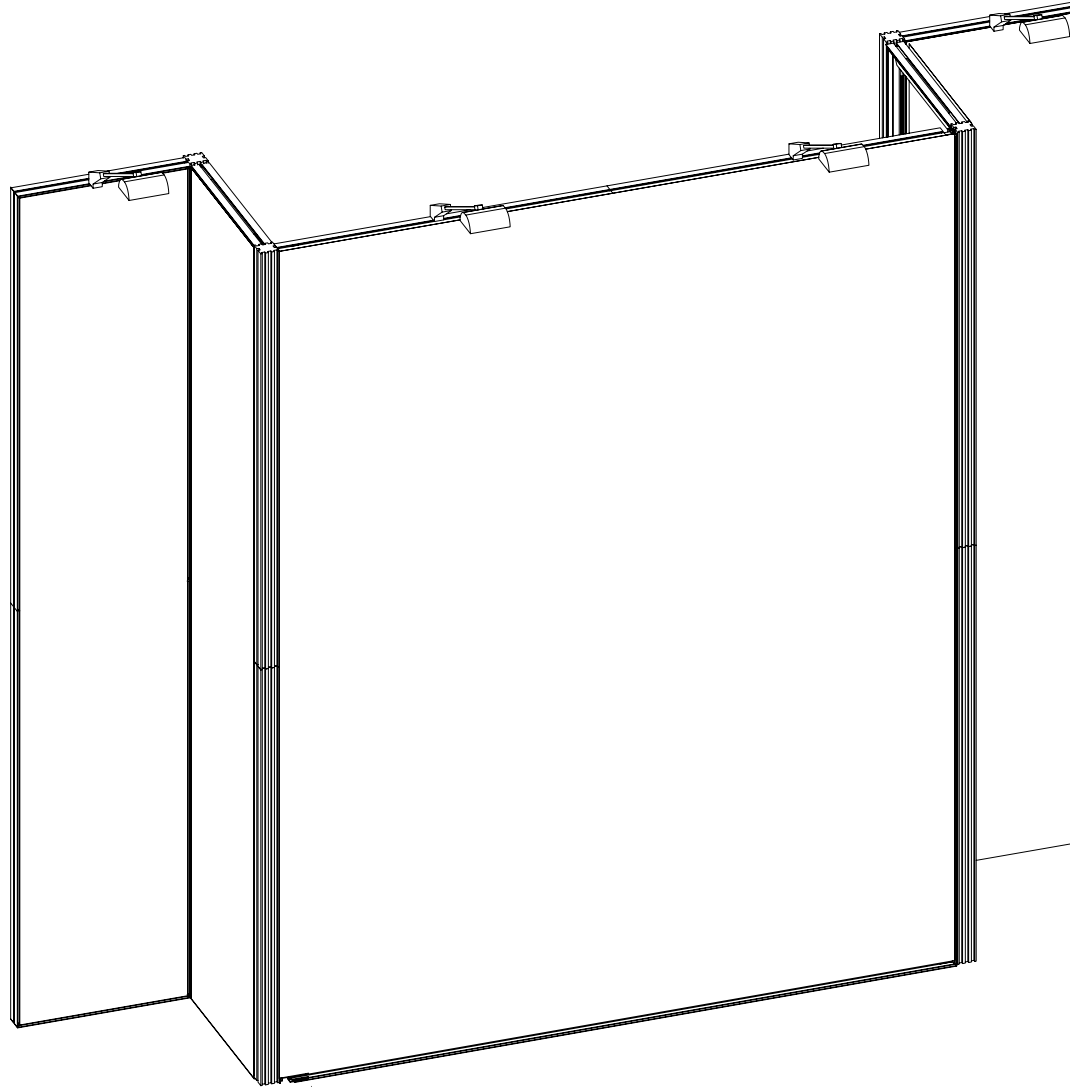

### Step 1. Assemble Section C

Arrange pieces on the floor as shown in the diagram below. Connect the F8s and F6s with lock connectors to create uprights. Connect the F2s with a lock connector. Connect the F16s and F13s with lock connectors to create horizontals. Insert a corner lock into both ends of the horizontals. Attach center upright to horizontals. Slide the corner locks in the horizontals into the remaining two uprights. When locking be sure to turn each cam a little bit and then go back and tighten both to the proper tension. Take care to turn locks only half a turn. All locks face back.

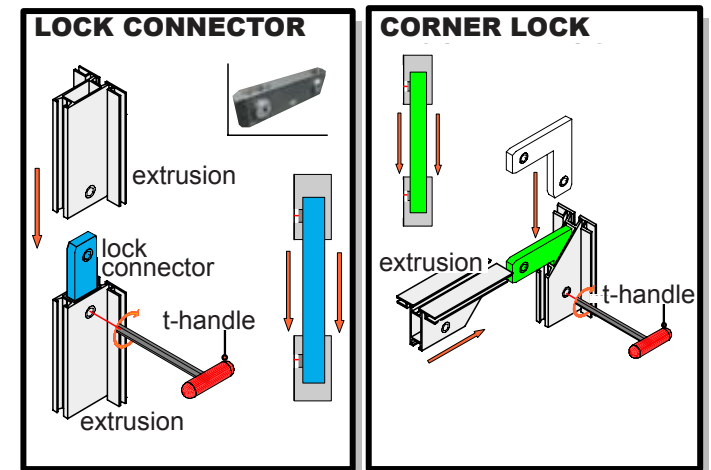
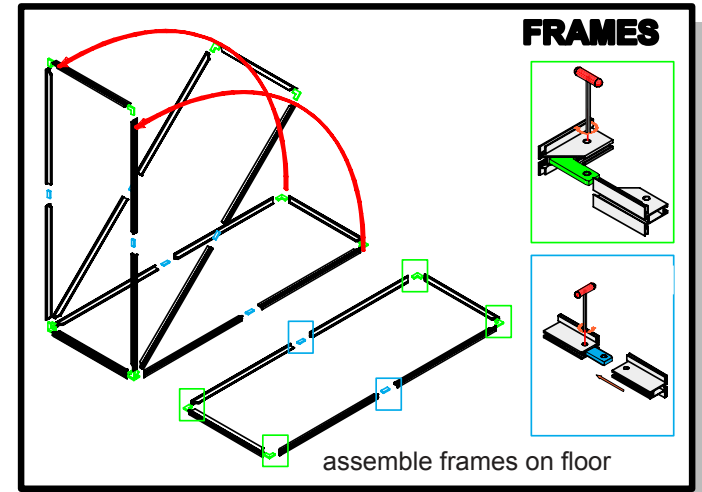
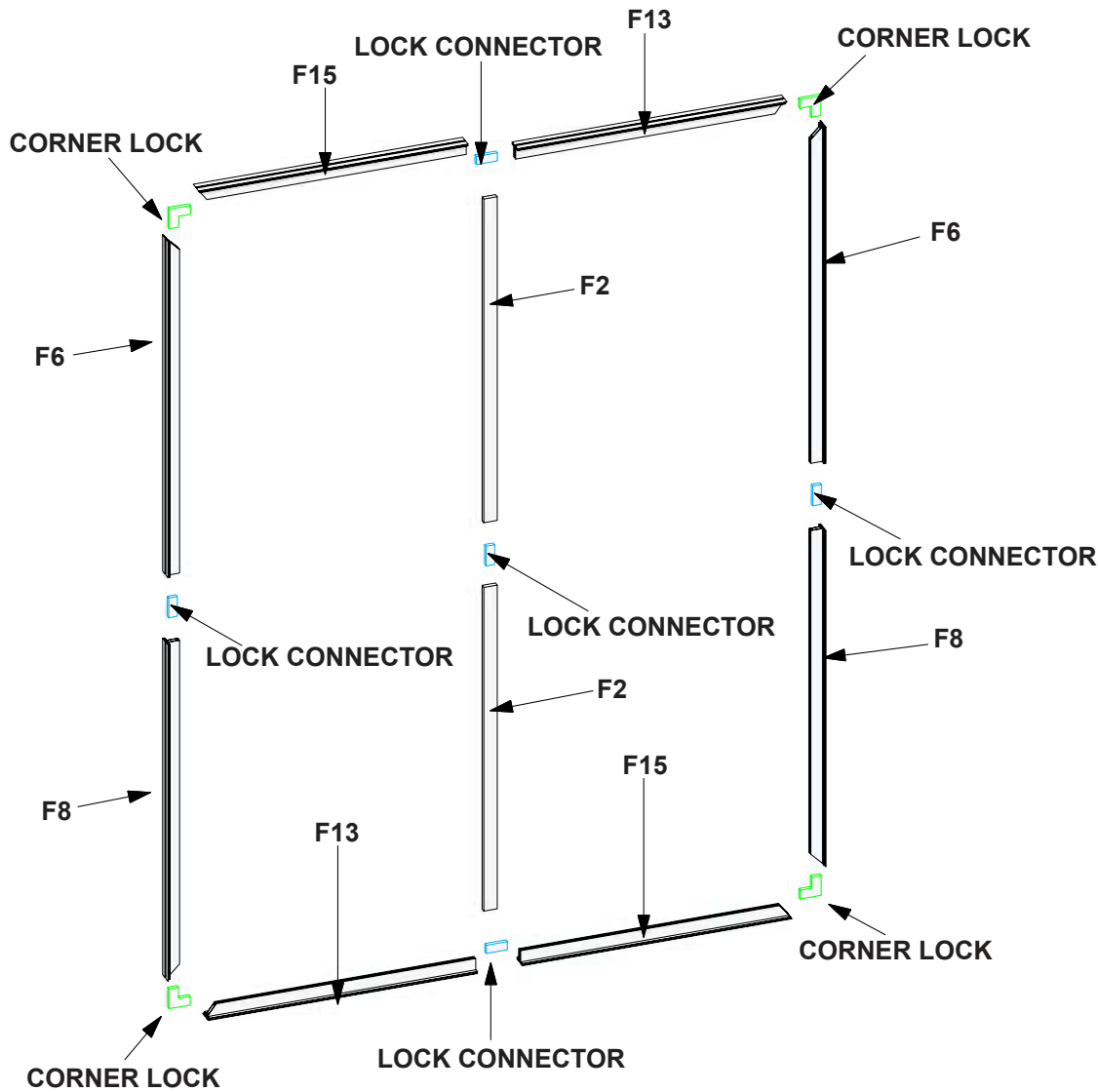

## Step 2. Put Graphic on Section C

Push the rubber gasket in edge of graphic into the channel on the frame. Start in upper left corner, go across the top and then down the sides to the bottom. Assure each graphic is tightly inserted. When taking graphics off, take care to gently pull by attached pull tab. Set frame aside.

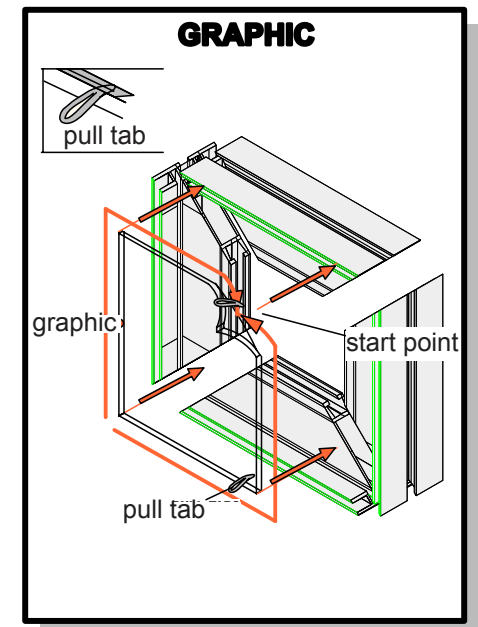
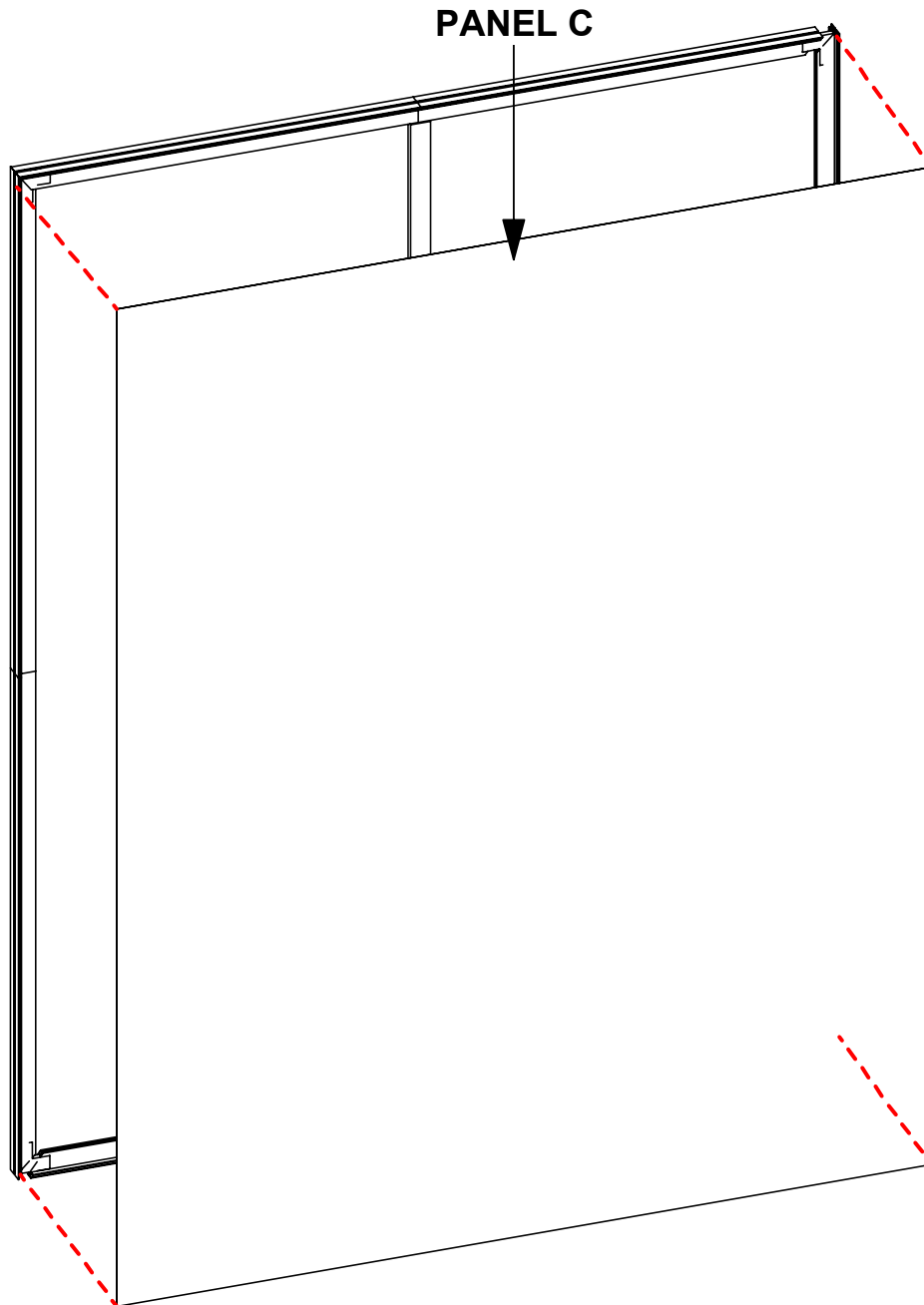

**SECTION C**

### Step 3. Assemble Section A

Arrange pieces on the floor as shown in the diagram below. Connect the F8 and F6 with a lock connector. Connect the F7s with a lock connector. Insert a corner lock into place on either end of the F17s. Slide F17s into the uprights and assure all locks are tightened. All locks face back. Push the rubber gasket in edge of graphic into the channel on the frame. Start in upper left corner, go across the top and then down the sides to the bottom. Assure each graphic is tightly inserted. When taking graphics off, take care to gently pull by attached pull tab. Set frame aside.

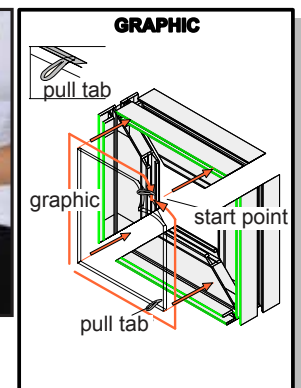
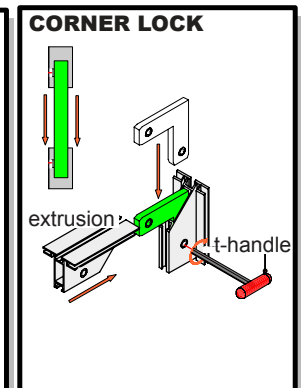
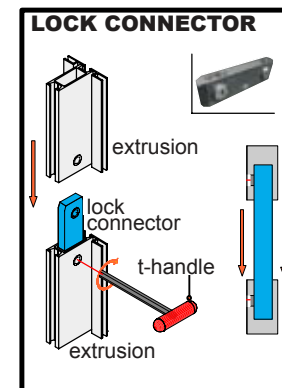
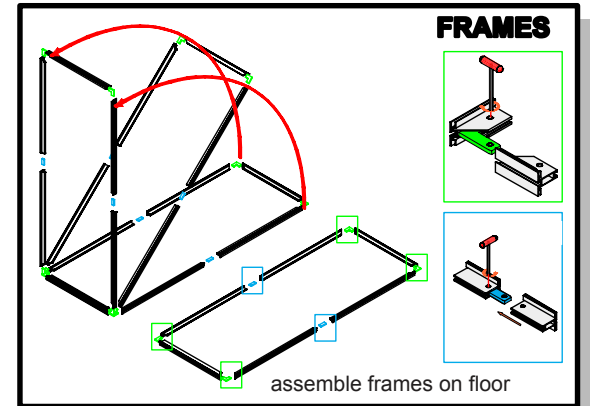
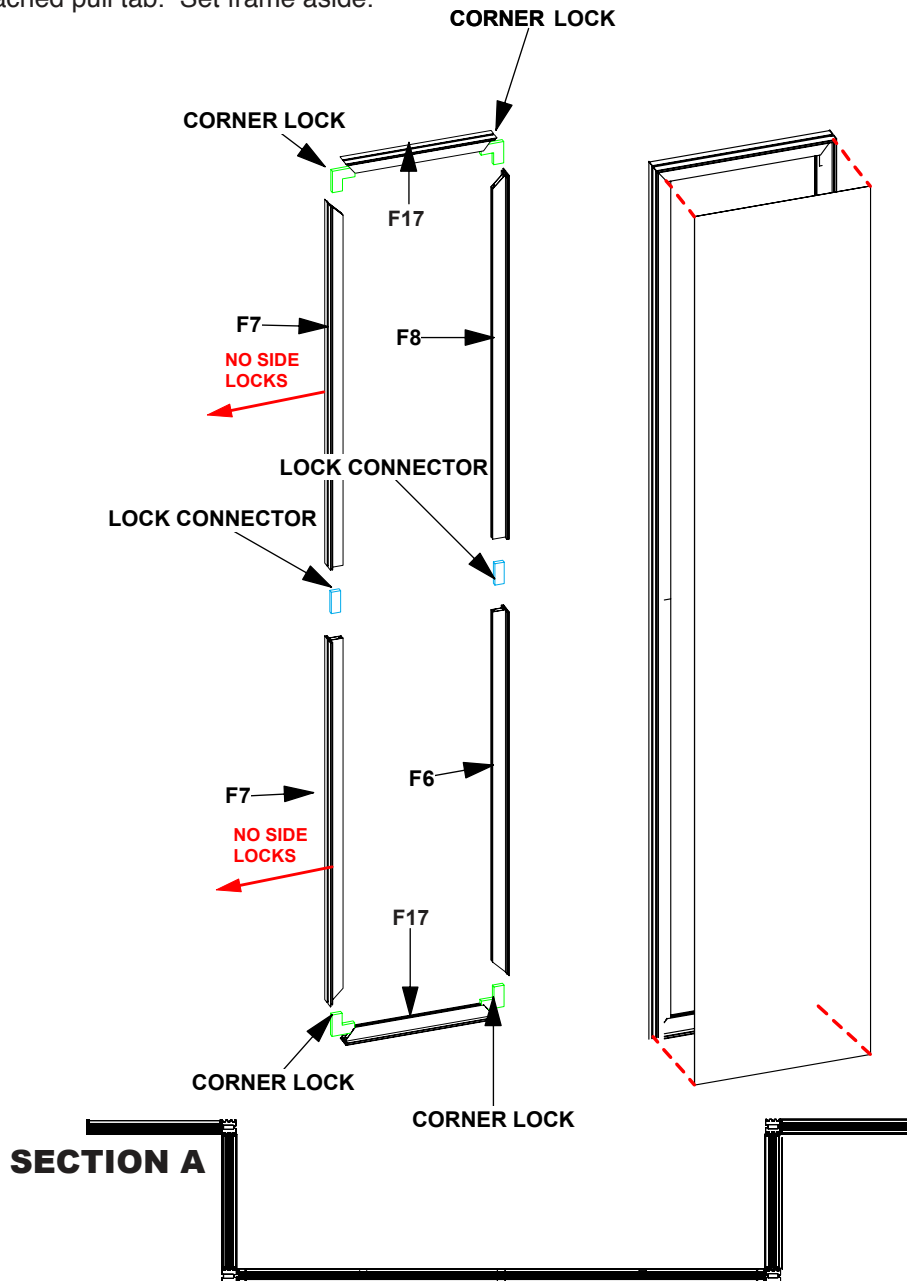

## Step 4. Assemble Section E

Arrange pieces on the floor as shown in the diagram below. Connect the F8 and F6 with a lock connector. Connect the F7s with a lock connector. Insert a corner lock into place on either end of the F17s. Slide F17s into the uprights and assure all locks are tightened. All locks face back. Push the rubber gasket in edge of graphic into the channel on the frame. Start in upper left corner, go across the top and then down the sides to the bottom. Assure each graphic is tightly inserted. When taking graphics off, take care to gently pull by attached pull tab. Set frame aside.

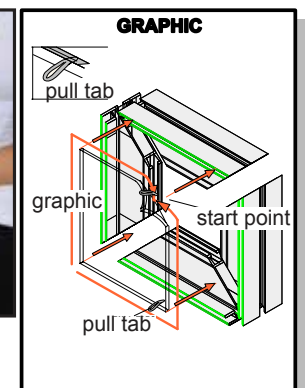
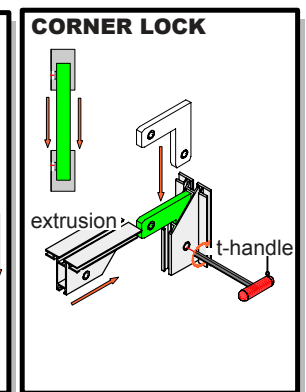
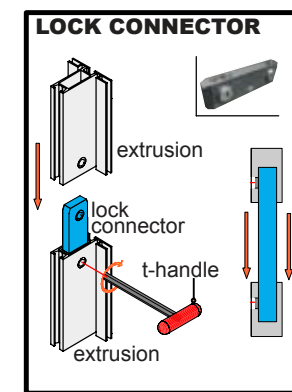
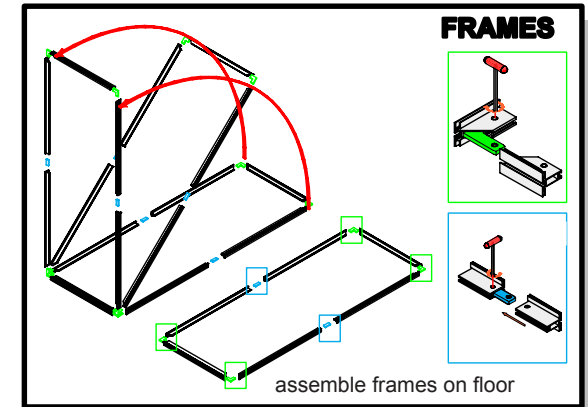
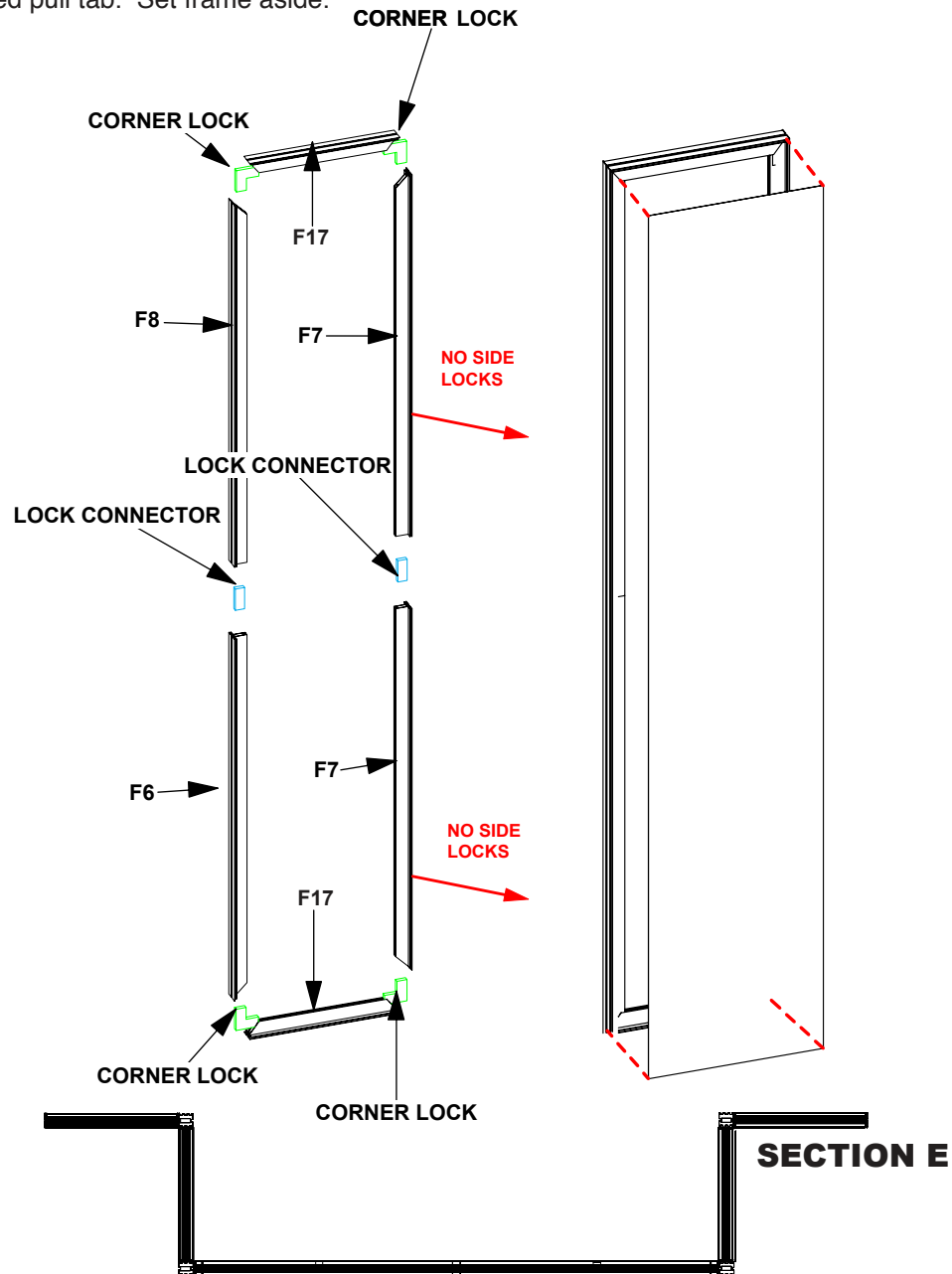

## Step 5. Assemble Sections B & D

Arrange pieces on the floor as shown in the diagram below. Connect the F8s and F6s with a lock connector. Insert a corner lock into place on either end of the F17s. Slide F17s into the uprights and assure all locks are tightened. All locks face back. Push the rubber gasket in edge of graphic into the channel on the frame. Start in upper left corner, go across the top and then down the sides to the bottom. Assure each graphic is tightly inserted. When taking graphics off, take care to gently pull by attached pull tab. Set frame aside.

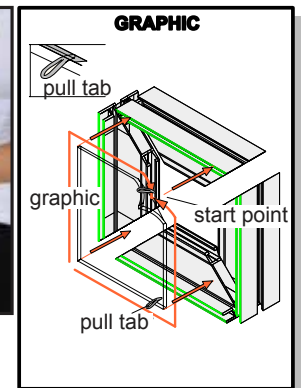
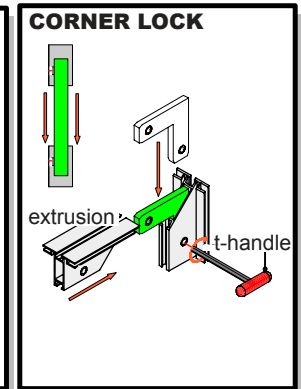
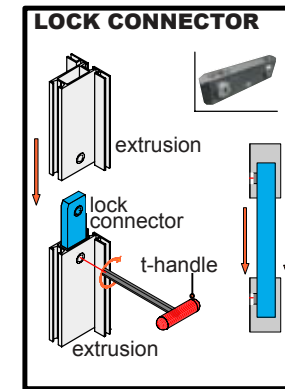
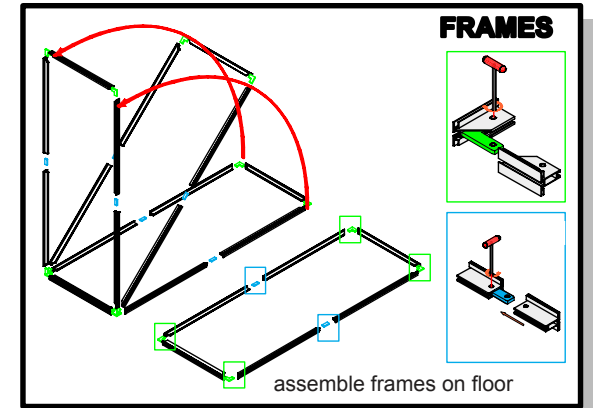
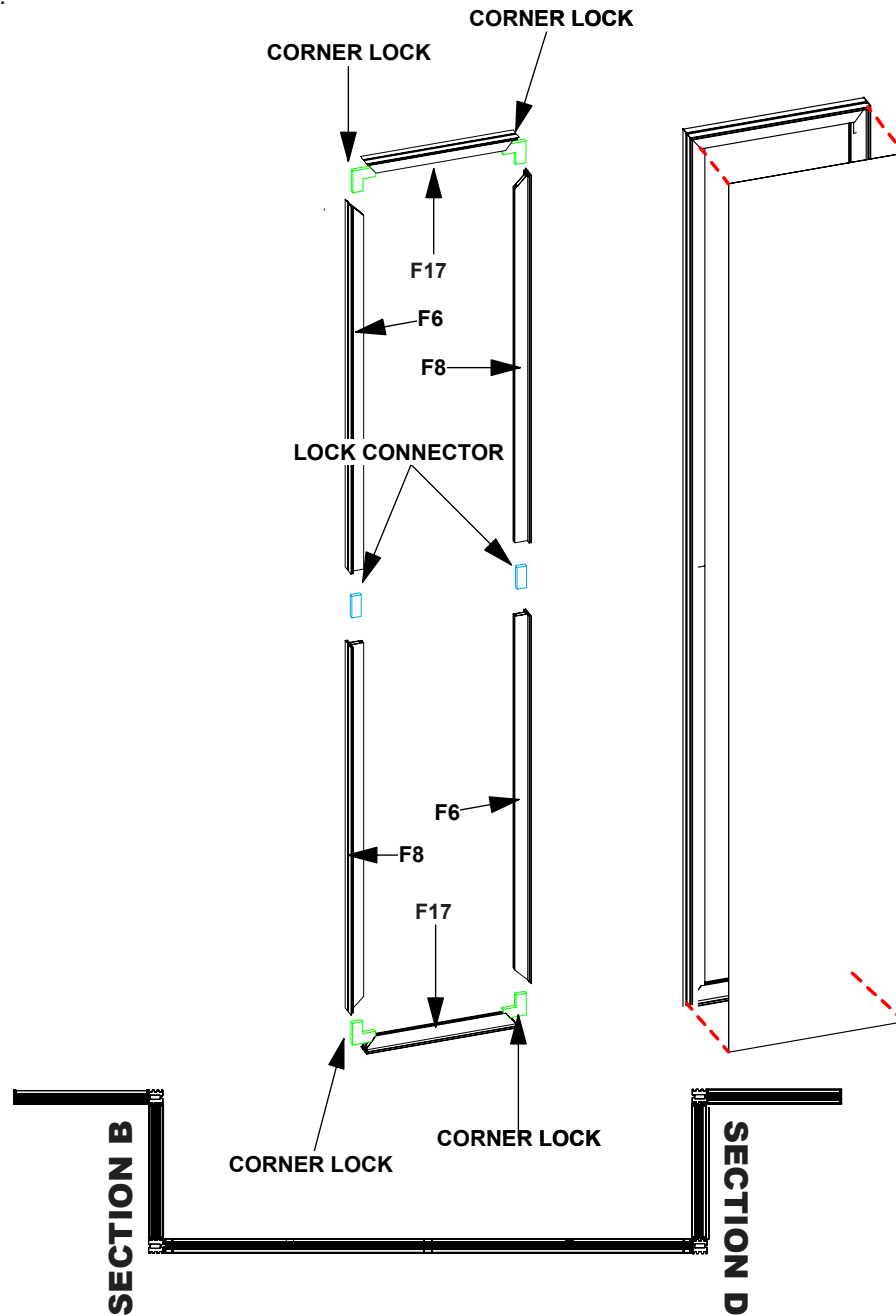



Step 6.

Slide the VE-45 into the lower VE-39s as shown in detail below. Slide upper VE-39s over VE-45s to create uprights.

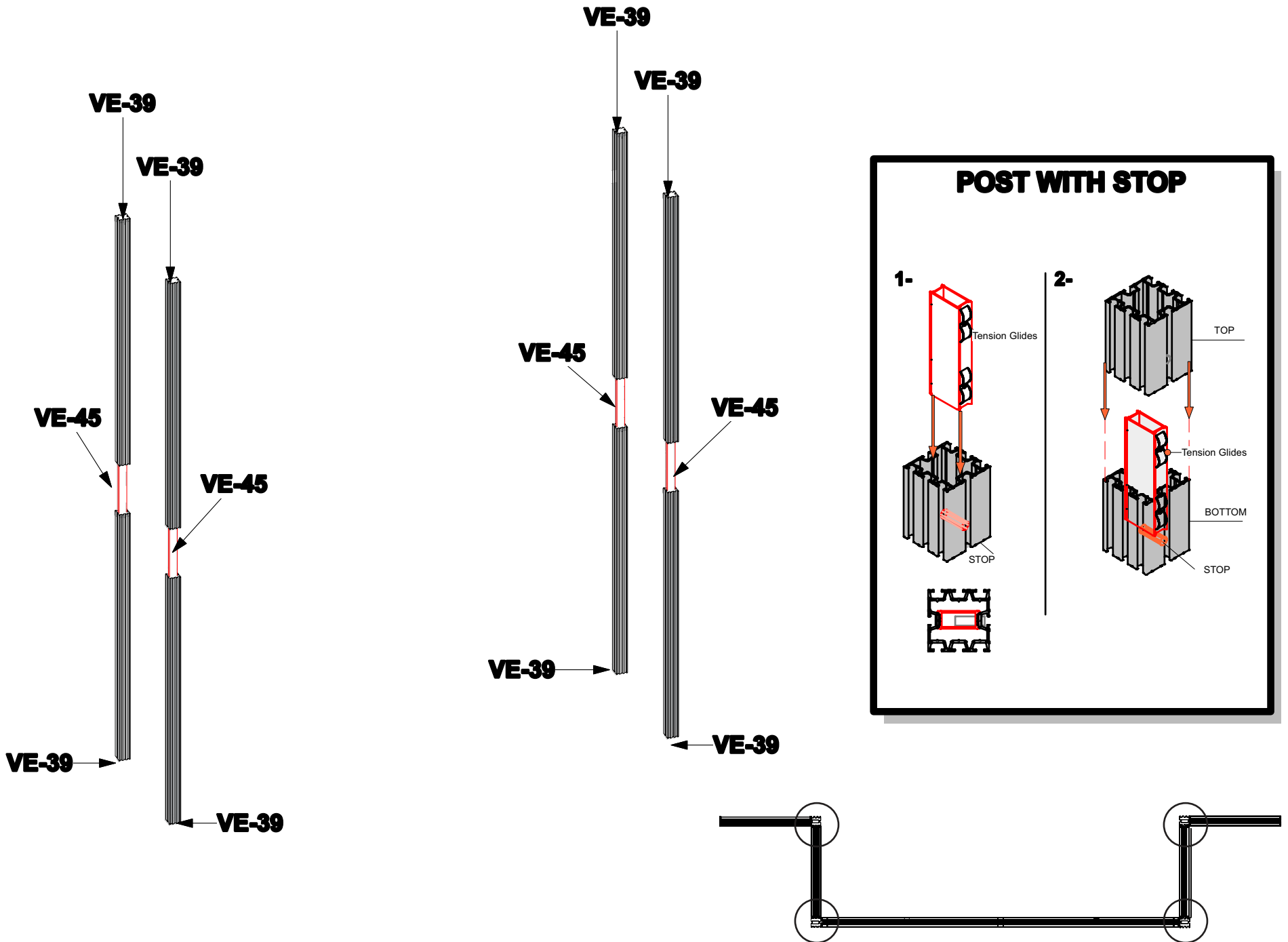

Step 7.

Lock completed uprights to the frame where shown using detail below.

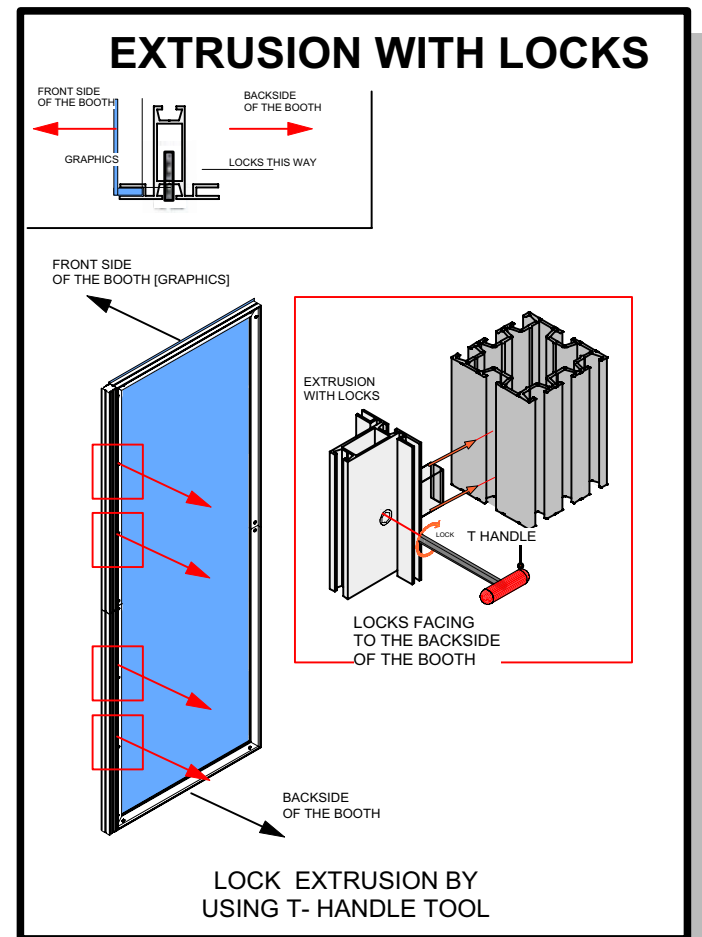
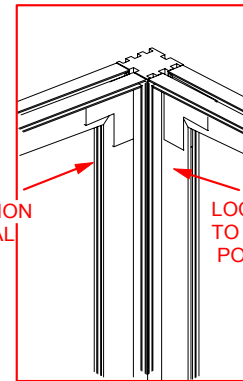
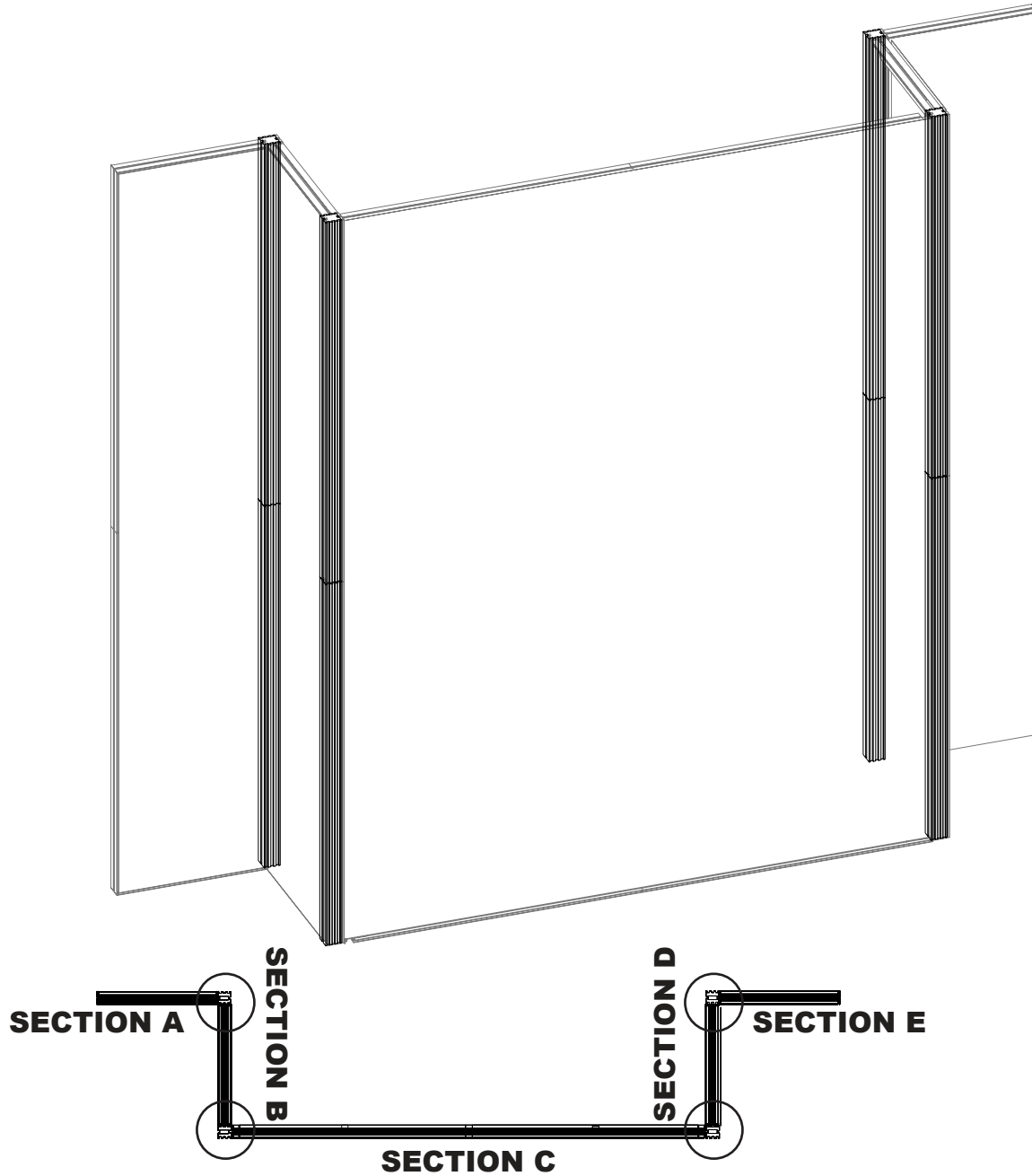

**Step 8.**

Attach lights to included clips by sliding onto ridges. Set clip in channel on top of frame as shown in detail below.

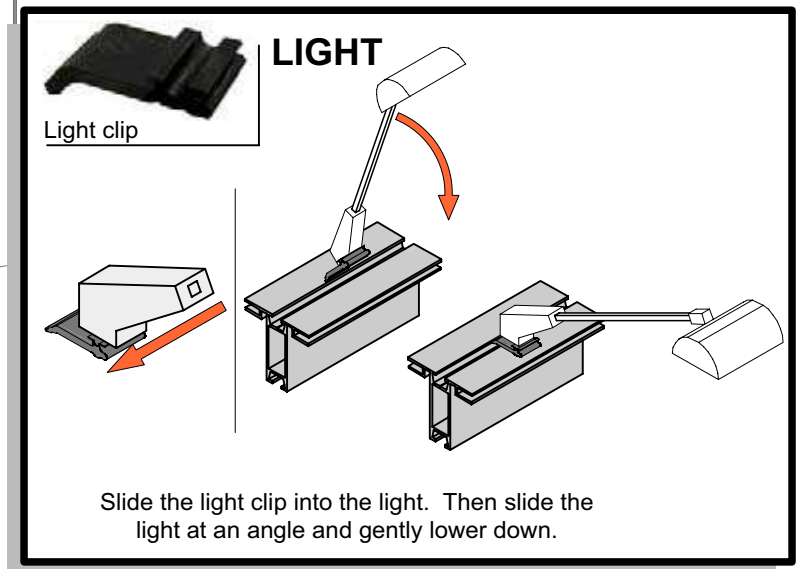
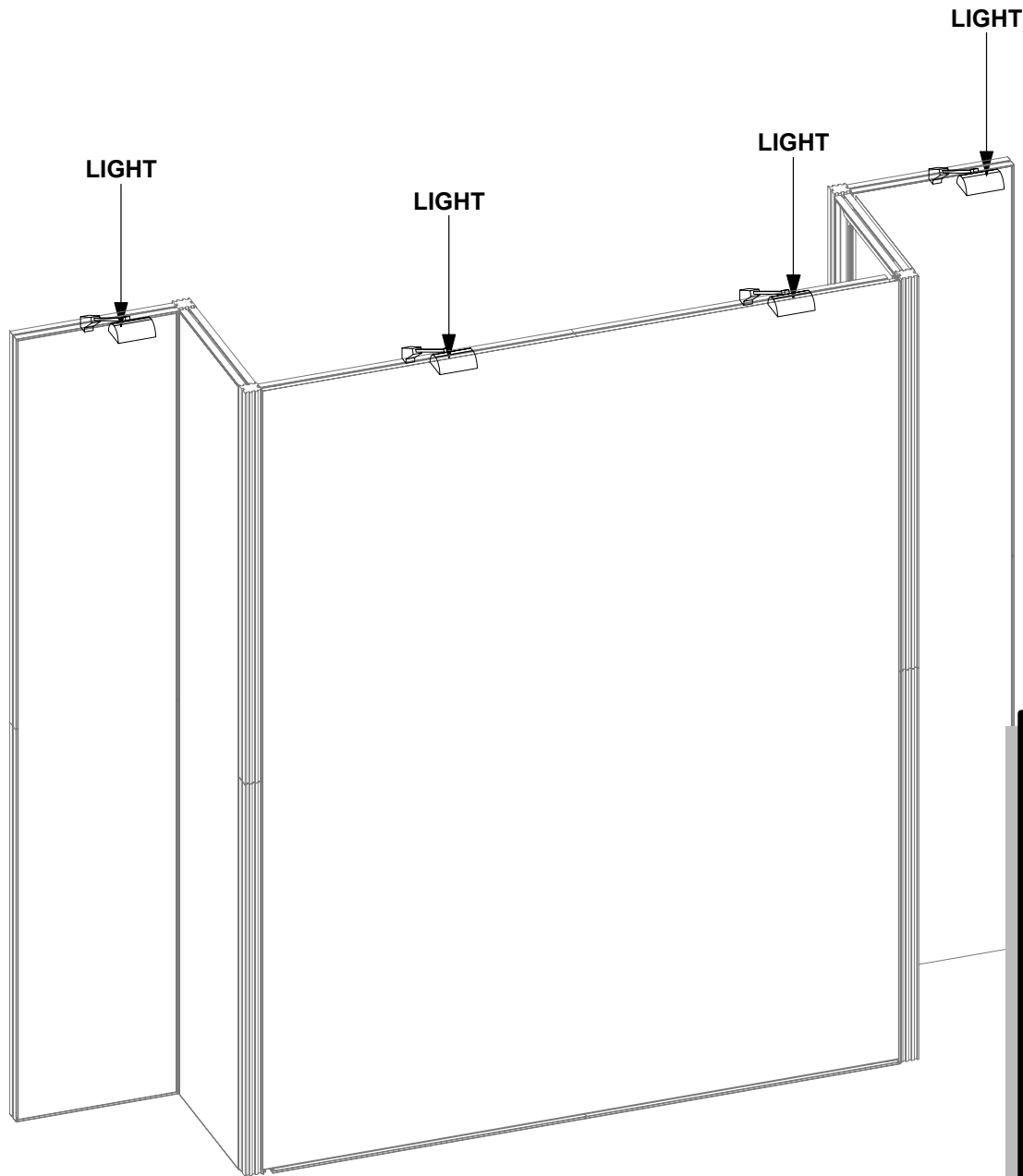

Parts included		
Part Label	Qty	Part code
F10	x4	PHFC2-900-1
F11	x8	PHFC2-900-1L
Corner lock	x16	CB9
F17	x4	PHRC2-450-1
VE-66	x4	PM2S-900
Countertop	x1	SW-CT-01
Panel A	x1	-
Panel B	x1	-
Panel C	x1	-
Panel D	x1	-

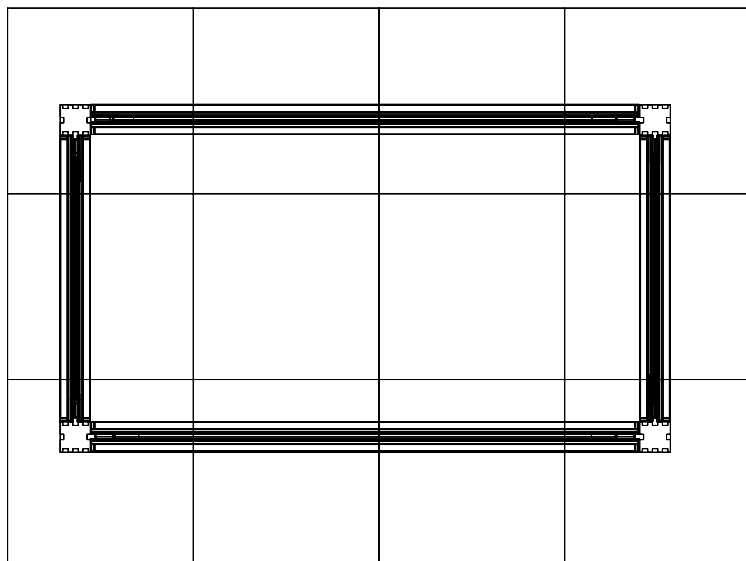
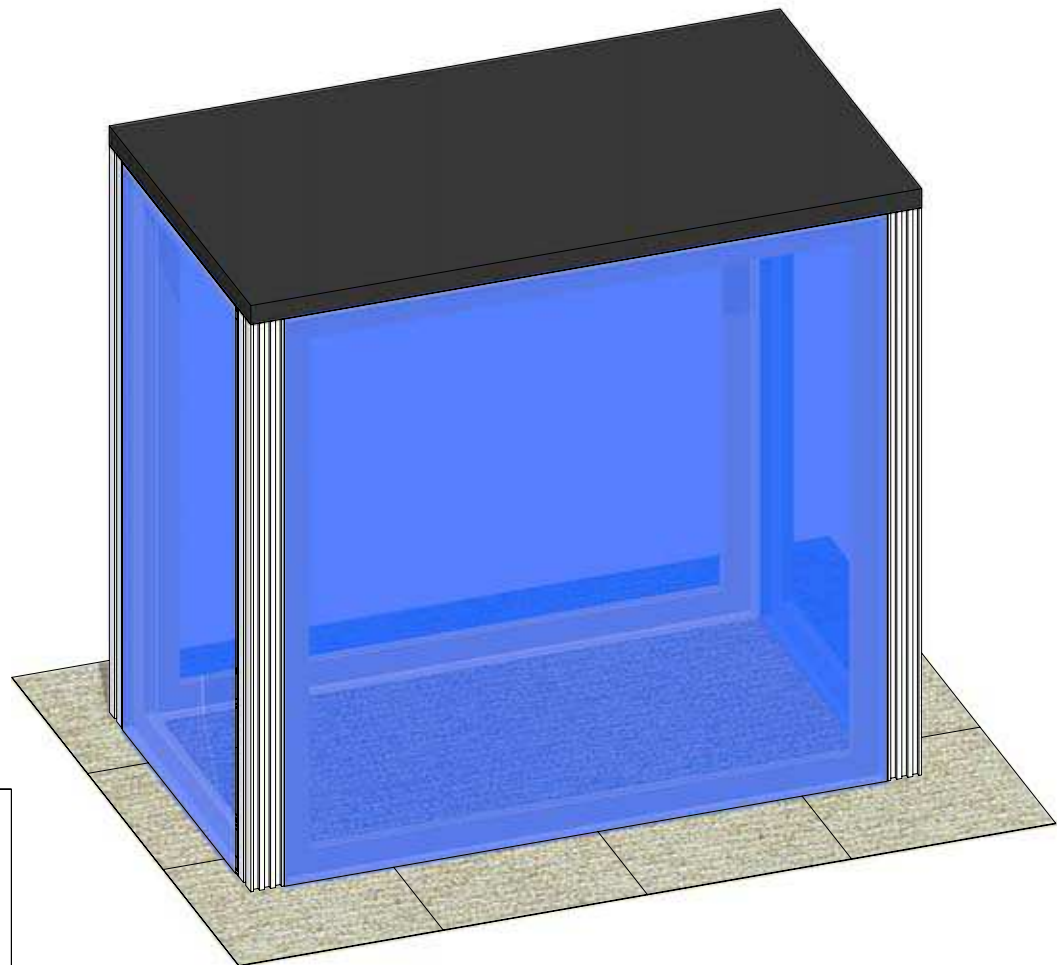

## Step 1. Assemble Counter Front & Back

Connect F10s to F11s using corner locks as shown in the detail below. Push the rubber gasket in edge of graphic into the channel on the frame. Start in upper left corner, go across the top and then down the sides to the bottom. Assure each graphic is tightly inserted. When taking graphics off, take care to gently pull by attached pull tab. Set frames aside.

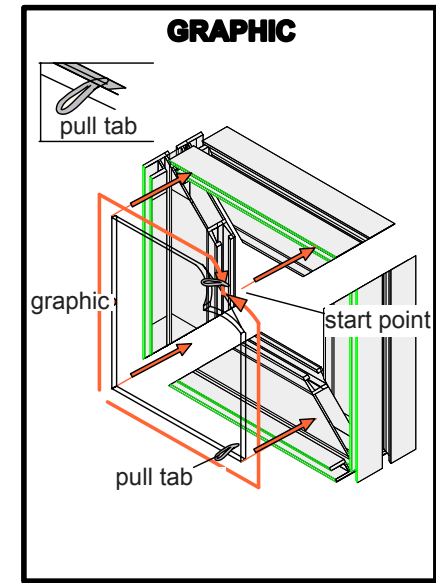
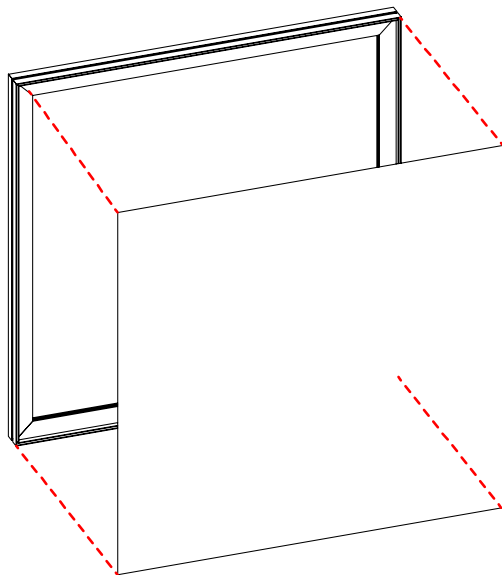
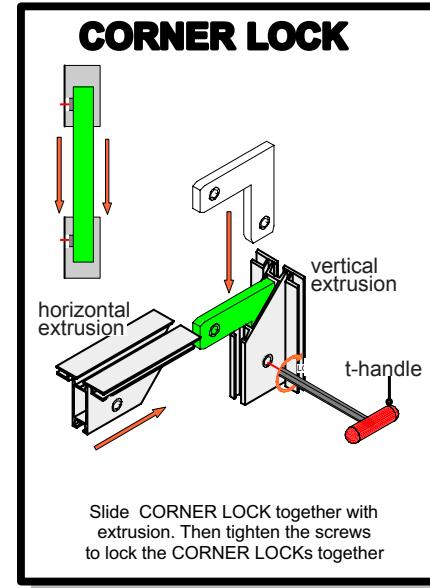
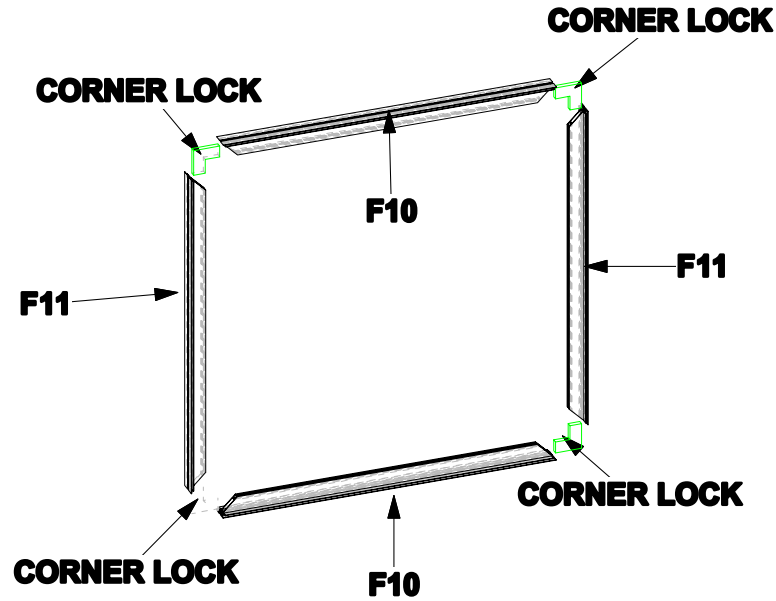

## Step 2. Build Counter Sides

Connect F17s to F11s using corner locks as shown in the detail below to build one rectangle. Push the rubber gasket in edge of graphic into the channel on the frame. Start in upper left corner, go across the top and then down the sides to the bottom. Assure each graphic is tightly inserted. When taking graphics off, take care to gently pull by attached pull tab. Set frames aside.

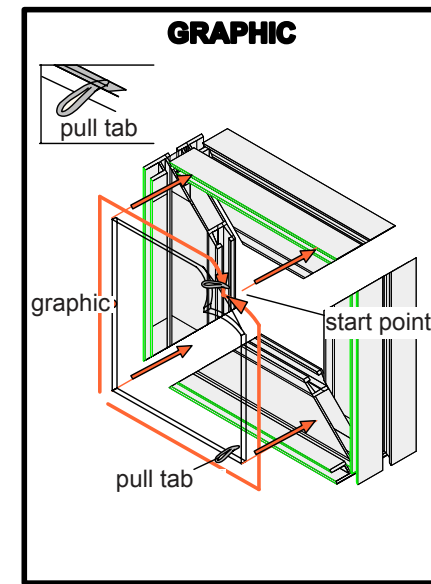
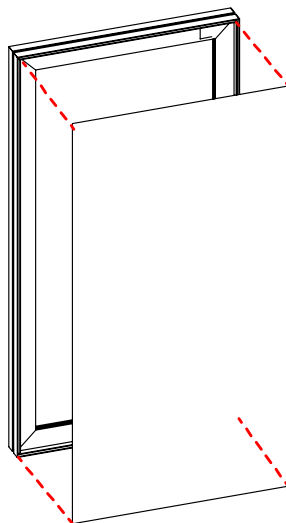
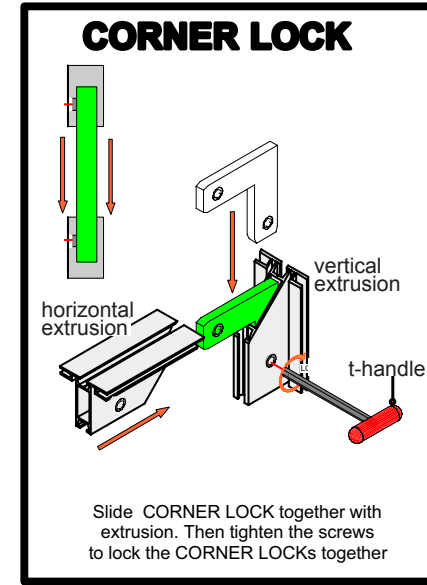
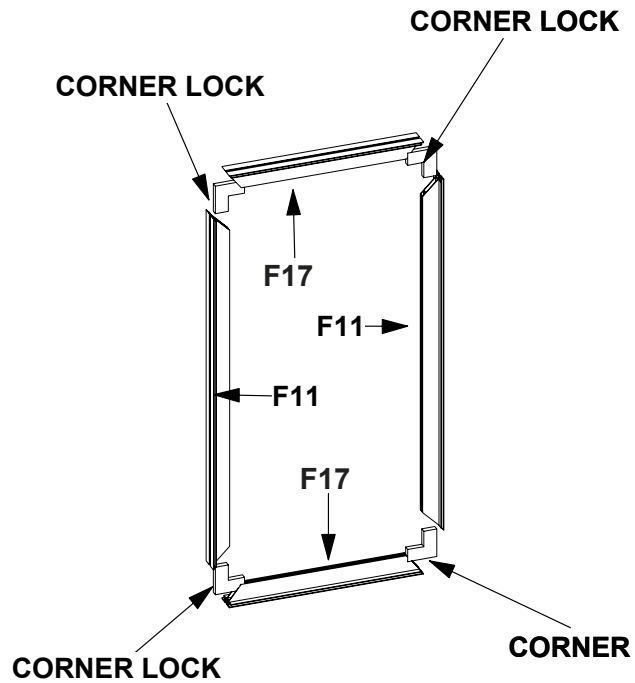

**Step 3.**

Attach the VE-66s to the completed counter sections where shown using the detail below.

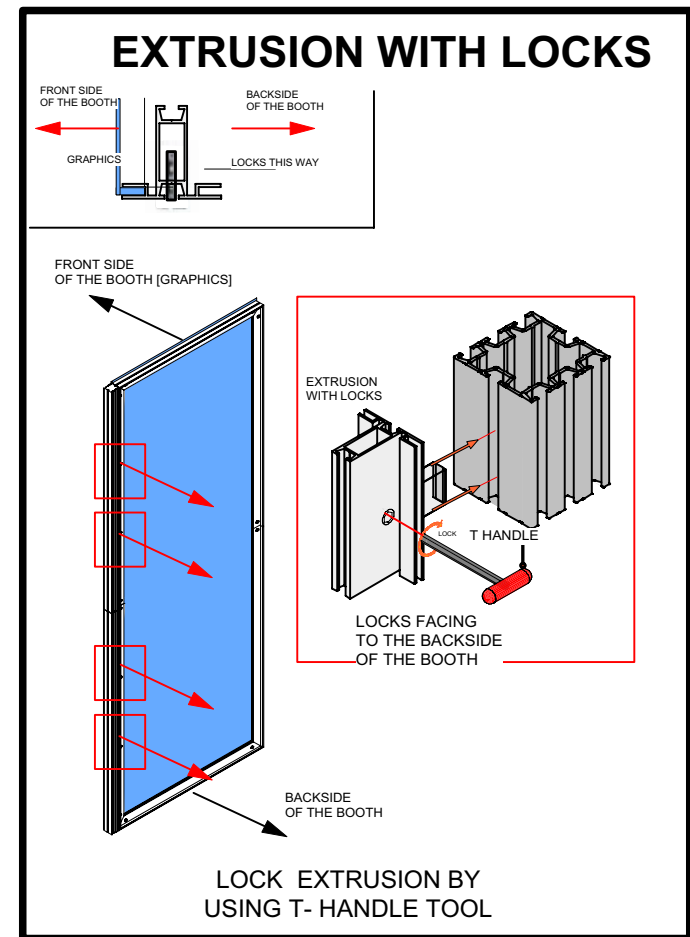
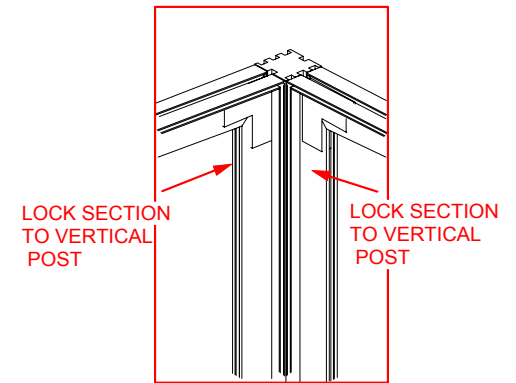
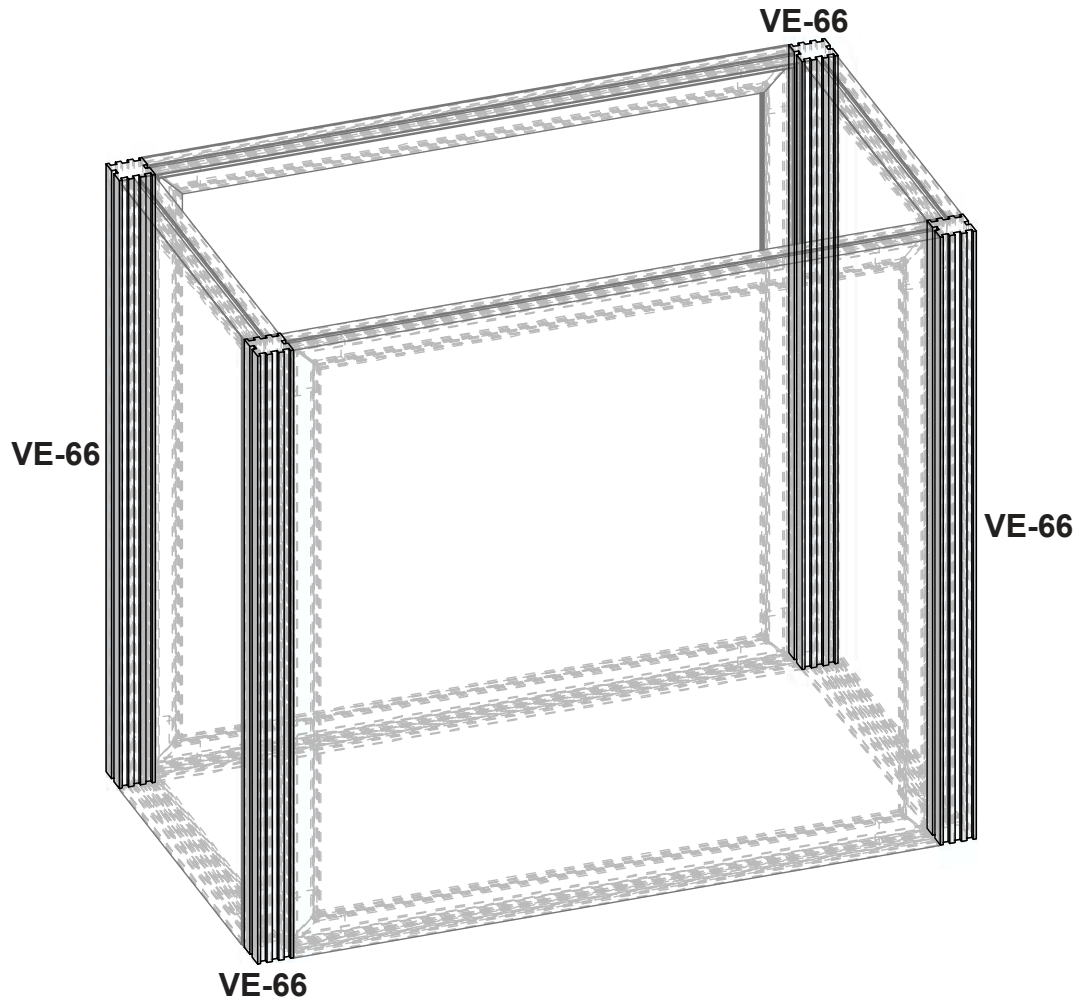

Step 4.  
Gently place the countertop onto the completed frame.

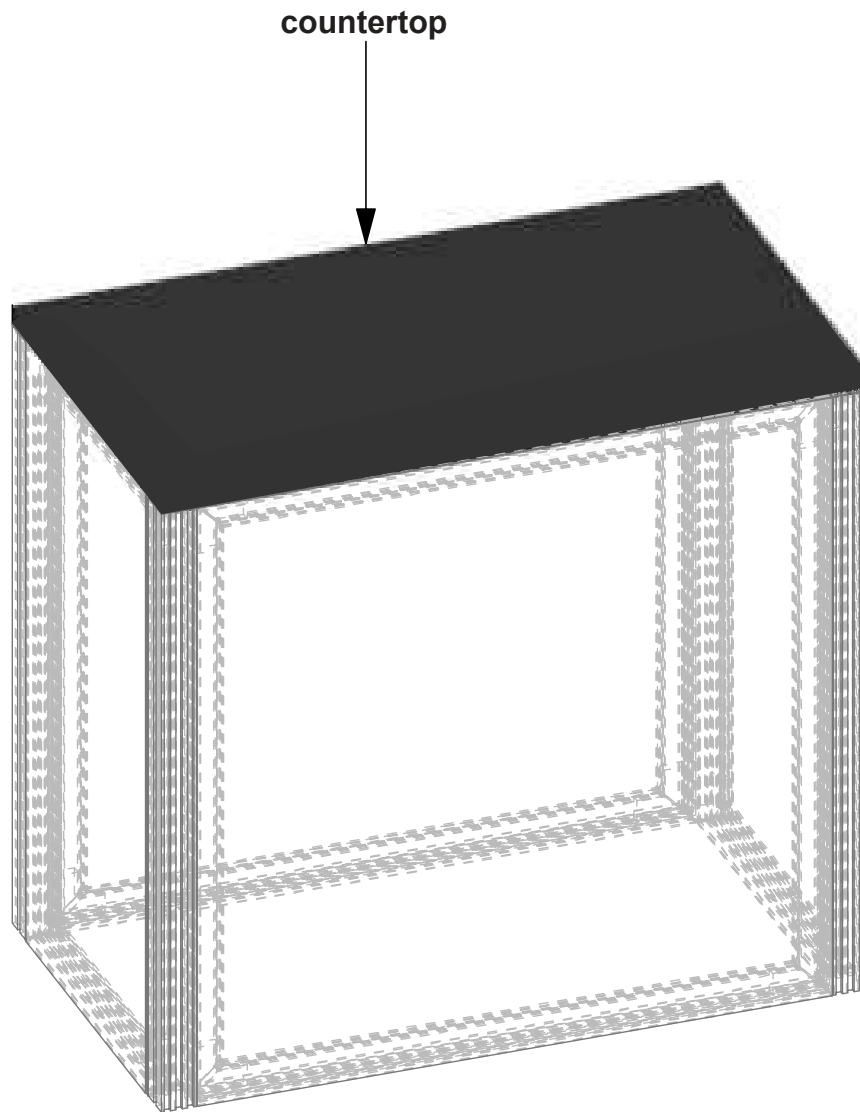



# Check out these related products:

---



Vector Frame Kit 01



Vector Frame Kit 02



Vector Frame Kit 03

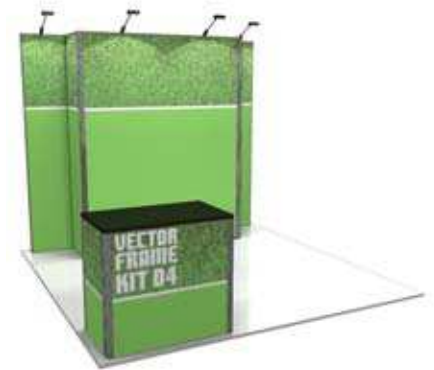

Vector Frame Kit 04



Vector Frame Kit 05

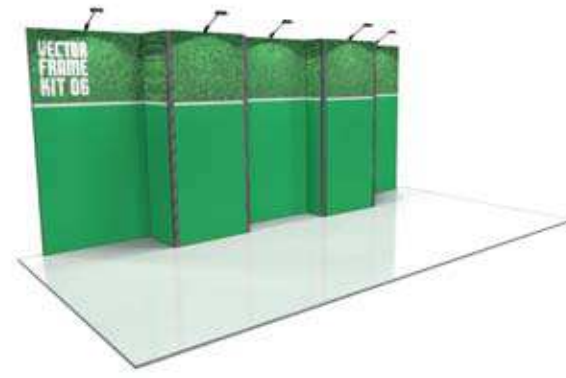

Vector Frame Kit 06



Vector Frame Kit 07



Vector Frame Kit 08

---